



WAAS CH 86902 W24A	APP CRS 241°	Rwy Idg TDZE Apt Elev	5000 16 18
---------------------------------	------------------------	-----------------------------	---------------------------------------

RNAV (GPS) RWY 24

BOWERMAN (HQM)

⚠ For uncompensated Baro-VNAV systems, LNAV/VNAV NA below -6°C (22°F) or above 43°C (109°F). When local altimeter setting not received, procedure NA. Circling NA northwest of Rwy 6-24. DME/DME RNP-0.3 NA. For inoperative MALSR, increase LPV Cat C visibility to 3/8 mile and LNAV Cat C visibility to 2 1/2 miles.

MALSR
 MISSED APPROACH: Climb to 2600 direct ZUNAD and hold.

ASOS 135.775	SEATTLE CENTER 128.3 269.0	UNICOM 122.7 (CTAF) 
------------------------	--------------------------------------	---

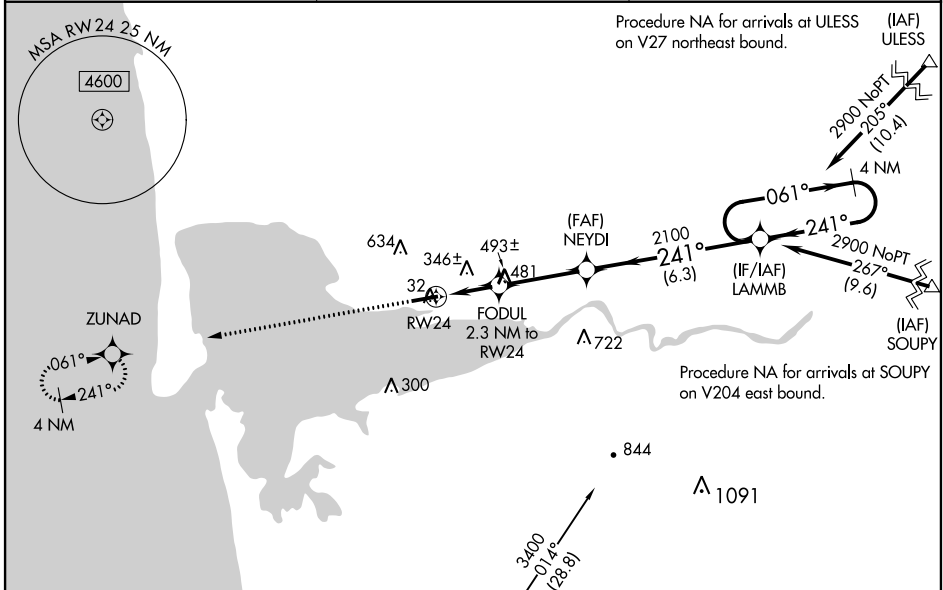

ELEV 18	TDZE 16
---------	---------

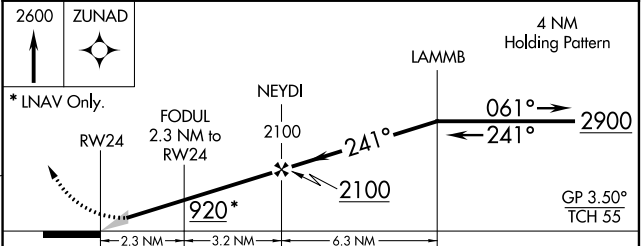
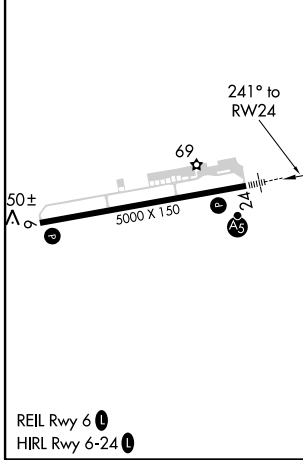

CATEGORY	A	B	C	D
LPV DA	226-1/2	210 (300-1/2)	286-1/2 270 (300-1/2)	NA
LNAV/VNAV DA	676-1 1/2 660 (700-1 1/2)			NA
LNAV MDA	800-1/2 784 (800-1/2)	800-3/4 784 (800-3/4)	800-1 3/4 784 (800-1 3/4)	NA
CIRCLING	800-1 782 (800-1)	800-1 1/4 782 (800-1 1/4)	800-2 1/2 782 (800-2 1/2)	NA

NW-1, 25 FEB 2021 to 25 MAR 2021

NW-1, 25 FEB 2021 to 25 MAR 2021