

WAAS CH 82211 W25B	APP CRS 258°	Rwy Idg TDZE Apt Elev	7800 1126 1135
--	------------------------	-----------------------------	---

RNAV (GPS) Y RWY 25L

PHOENIX SKY HARBOR INTL (PHX)

⚠ For inop ALS, increase visibility LNAV/VNAV all Cats to 1½ SM. For uncompensated Baro-VNAV systems, LNAV/VNAV NA below -17°C (2°F) or above 46°C (114°F). DME/DME RNP-0.3 NA. Simultaneous approach authorized with ILS or LOC Rwy 26. Use of FD or AP providing RNAV track guidance required during simultaneous operations. LNAV procedure NA during simultaneous operations.

MALSR

MISSED APPROACH: Climb to 5000 direct OVNUY and via 261° track to BKK VORTAC and hold.

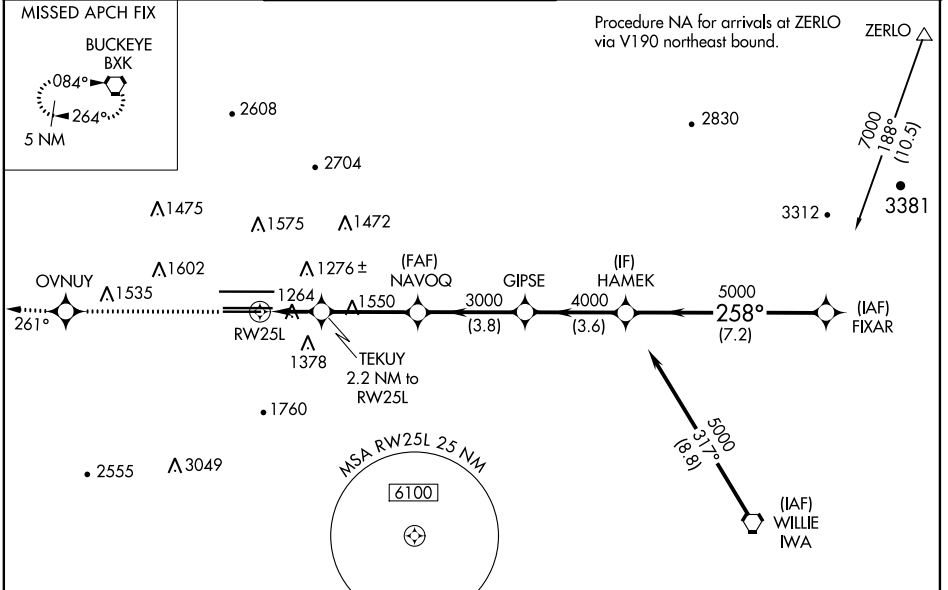
D-ATIS 127.575	PHOENIX APP CON 128.65 353.9	PHOENIX TOWER 118.7 278.8 (Rwy 8-26) 120.9 254.3 (Rwy 7L-25R, 7R-25L)	GND CON 119.75 269.2 (N) 132.55 269.2 (S)	CLNC DEL 118.1 269.2	CPDLC
--------------------------	--	---	---	--------------------------------	-------

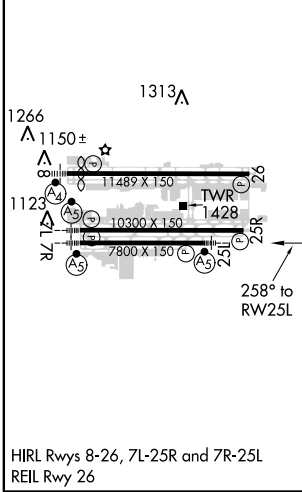

ELEV 1135	D	TDZE 1126
-----------	----------	-----------



5000	OVNUY	tr 261°	BKK	VGSI and RNAV glidepath not coincident (VGSI Angle 3.00/TCH 66).			
*LNAV only.		TEKUY 2.2 NM to RW25L	NAVOQ	GIPSE	HAMEK	FIXAR	
1.5 NM to RW25L		*1.5 NM to RW25L	1880*	3000	4000	5000	7000
1.5 NM		0.7 NM	3.4 NM	3.8 NM	3.6 NM	7.2 NM	
CATEGORY	A	B	C	D			
LPV DA	1482-¾		356 (400-¾)				
LNAV/VNAV DA	1613-¼		487 (500-1¼)				
LNAV MDA	1680-½	554 (600-½)	1680-1⅞	554 (600-1⅞)	1680-1¼	554 (600-1¼)	
C CIRCLING	1740-1	605 (700-1)	2040-2¾	905 (1000-2¾)	2560-3	1425 (1500-3)	

SW-4, 25 FEB 2021 to 25 MAR 2021

SW-4, 25 FEB 2021 to 25 MAR 2021