

WAAS CH 70321 W26A	APP CRS 258°	Rwy Idg 11489 TDZE 1135 Apt Elev 1135
--	------------------------	--

RNAV (GPS) Y RWY 26

PHOENIX SKY HARBOR INTL (PHX)

⚠ For uncompensated Baro-VNAV systems, LNAV/VNAV NA below -17°C (2°F) or above 46°C (114°F). DME/DME RNP-0.3 NA. Simultaneous approach authorized with ILS or LOC Rwy 25L. Use of FD or AP providing RNAV track guidance required during simultaneous operations. LNAV procedure NA during simultaneous operations.

MISSED APPROACH:
Climb to 5000 direct OJGIL and via 259° track to BKK VORTAC and hold.

D-ATIS 127.575	PHOENIX APP CON 128.65 353.9	PHOENIX TOWER 118.7 278.8 (Rwy 8-26) 120.9 254.3 (Rwy 7L-25R, 7R-25L)	GND CON 119.75 269.2 (N) 132.55 269.2 (S)	CLNC DEL 118.1 269.2	CPDLC
--------------------------	--	---	---	--------------------------------	-------

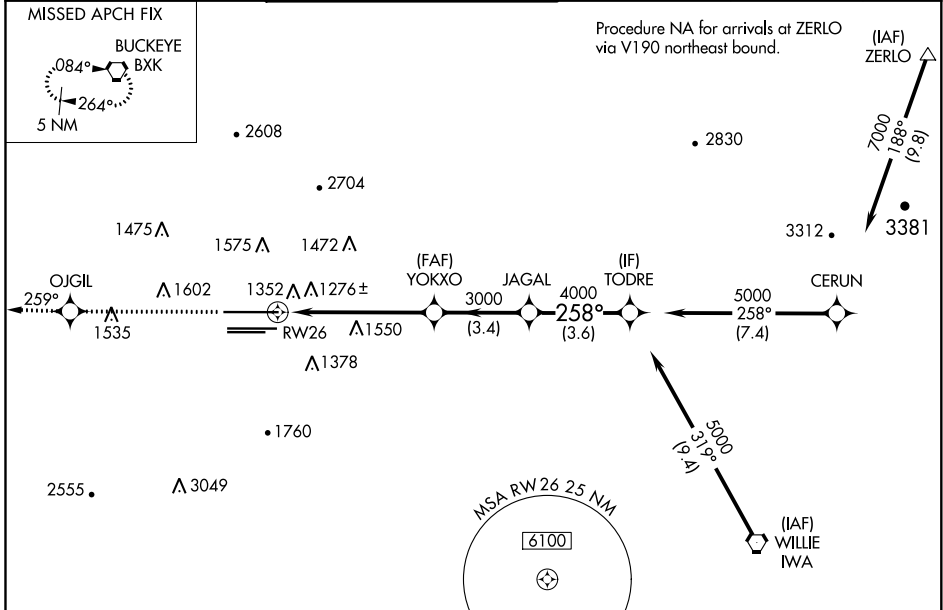

ELEV 1135	D	TDZE 1135
-----------	----------	-----------

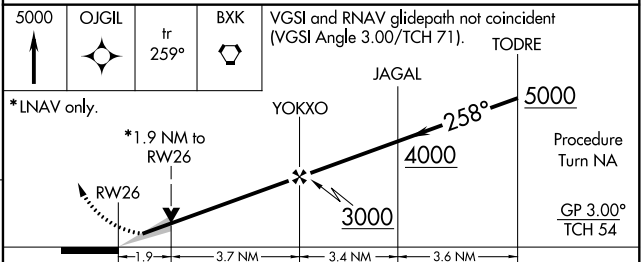
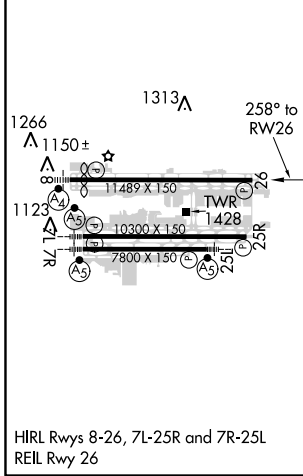

CATEGORY	A	B	C	D
LPV DA	1436-1 301 (400-1)			
LNAV/VNAV DA	1659-1¾ 524 (600-1¾)			
LNAV MDA	1800-1 665 (700-1)	1800-1¾ 665 (700-1¾)		1800-2 665 (700-2)
C CIRCLING	1800-1 665 (700-1)	2040-2¾ 905 (1000-2¾)		2560-3 1425 (1500-3)

SW-4, 25 FEB 2021 to 25 MAR 2021

SW-4, 25 FEB 2021 to 25 MAR 2021