

# SEATTLE SEVEN DEPARTURE

AL-582 (FAA)

SEATTLE-TACOMA INTL (SEA)  
SEATTLE, WASHINGTON

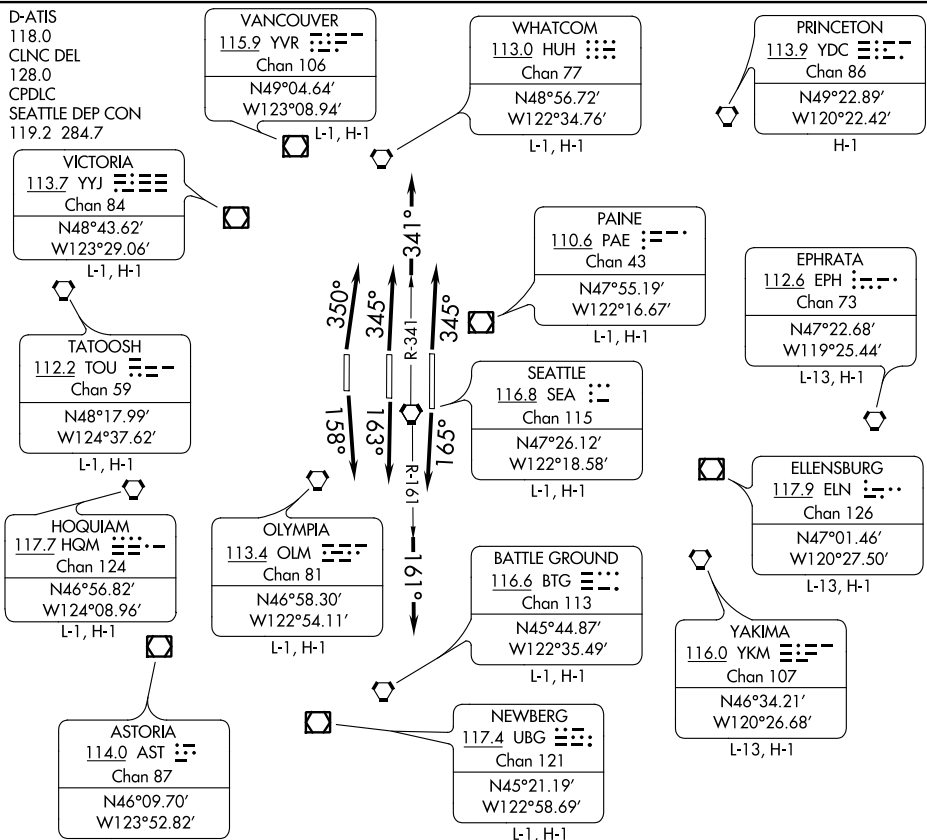

NW-1, 25 FEB 2021 to 25 MAR 2021

NW-1, 25 FEB 2021 to 25 MAR 2021

NOTE: RADAR required.

NOTE: Between the hours of 2200 and 0600 local, large turbine powered aircraft departing Rwy's 34L/C/R will be vectored over Puget Sound for noise abatement before proceeding on course.

**TAKEOFF MINIMUMS**  
Rwy's 16C, 34L, 34C, 34R: Standard.  
Rwy 16L: 300-1 or standard with minimum climb of 425' per NM to 600.  
Rwy 16R: 300-1¼ or standard with minimum climb of 215' per NM to 600.

NOTE: Chart not to scale.

## DEPARTURE ROUTE DESCRIPTION

- TAKEOFF RUNWAY 16L: Climb heading 165° and on SEA R-161, thence. . .
  - TAKEOFF RUNWAY 16C: Climb heading 163° and on SEA R-161, thence. . .
  - TAKEOFF RUNWAY 16R: Climb heading 158° and on SEA R-161, thence. . .
  - TAKEOFF RUNWAY 34L: Climb heading 350° and on SEA R-341, thence. . .
  - TAKEOFF RUNWAYS 34C/R: Climb heading 345° and on SEA R-341, thence. . .
- . . . maintain assigned altitude, expect RADAR vectors to assigned route.