

WAAS CH 97439 W27A	APP CRS 273°	Rwy Idg TDZE 879 Apt Elev 884	4649
--	------------------------	---	-------------

RNAV (GPS) RWY 27

NEWARK-HEATH (VTA)

⚠ Circling Rwy 9 NA at night. Rwy 27 helicopter visibility reduction below ¼ SM NA. DME/DME RNP-0.3 NA.

MISSED APPROACH: Climb to 2000 then climbing right turn to 3000 direct APE VORTAC and hold.

ASOS 121.125	COLUMBUS APP CON 125.95 317.775	CLNC DEL 125.175	UNICOM 122.7 (CTAF)	123.3 0
------------------------	---	----------------------------	-------------------------------	-----------------------

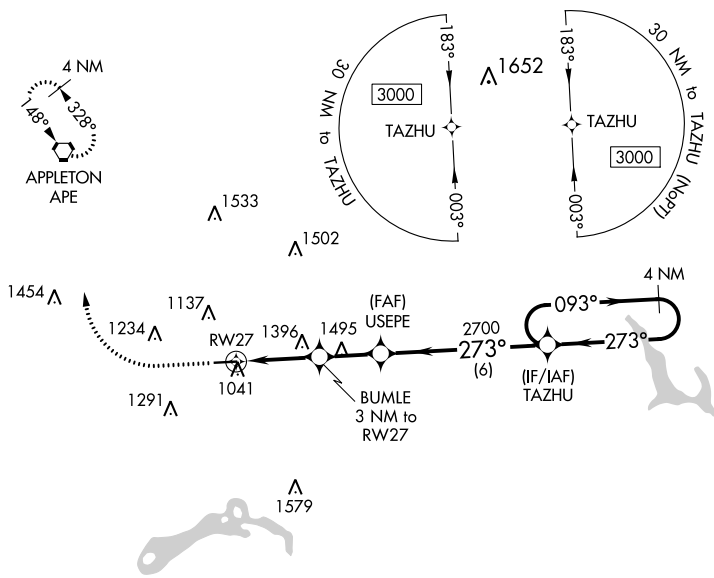

ELEV 884	TDZE 879
-----------------	-----------------

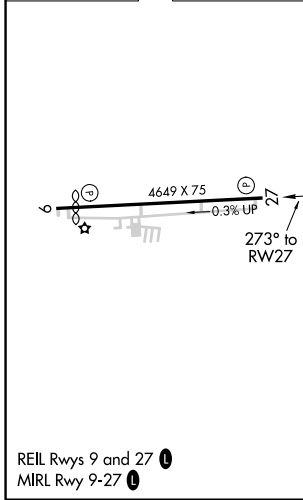

2000	3000	APE	VGSi and descent angles not coincident (VGSi Angle 3.25/TCH 20).		4 NM Holding Pattern
			USEPE	TAZHU	3000
			2700	273°	093°
			273°	273°	3000
CATEGORY	A	B	C	D	
LP MDA	1680-1 801 (800-1)	1680-1¼ 801 (800-1¼)	1680-2½	801 (800-2½)	
LNAV MDA	1700-1 821 (900-1)	1700-1¼ 821 (900-1¼)	1700-2½	821 (900-2½)	
C CIRCLING	1700-1¼	816 (900-1¼)	1760-2½ 876 (900-2½)	1760-2¾ 876 (900-2¾)	

EC-2, 25 FEB 2021 to 25 MAR 2021

EC-2, 25 FEB 2021 to 25 MAR 2021