

WAAS CH 82441 W29A	APP CRS 291°	Rwy Idg TDZE Apt Elev	3200 29 29
--	------------------------	-----------------------------	---------------------------------------

RNAV (GPS) RWY 29

BUCKLAND (BVK)(PABL)

RNP APCH.

▼ Rwy 29 helicopter visibility reduction below 3/4 SM NA. VDP NA when using Selawik altimeter setting. When Buckland altimeter setting not received, use Selawik altimeter setting and increase all MDA 120 feet, LNAV Cat C visibility 3/8 SM and Circling Cat C 1/4 SM.

▲ MISSED APPROACH: Climb to 2900 direct HAGVA and hold.

⊖ -36°C

AWOS-3P 135.15	ANCHORAGE CENTER 119.2 263.0	KOTZEBUE RADIO 122.3	CTAF 122.9
--------------------------	--	--------------------------------	----------------------

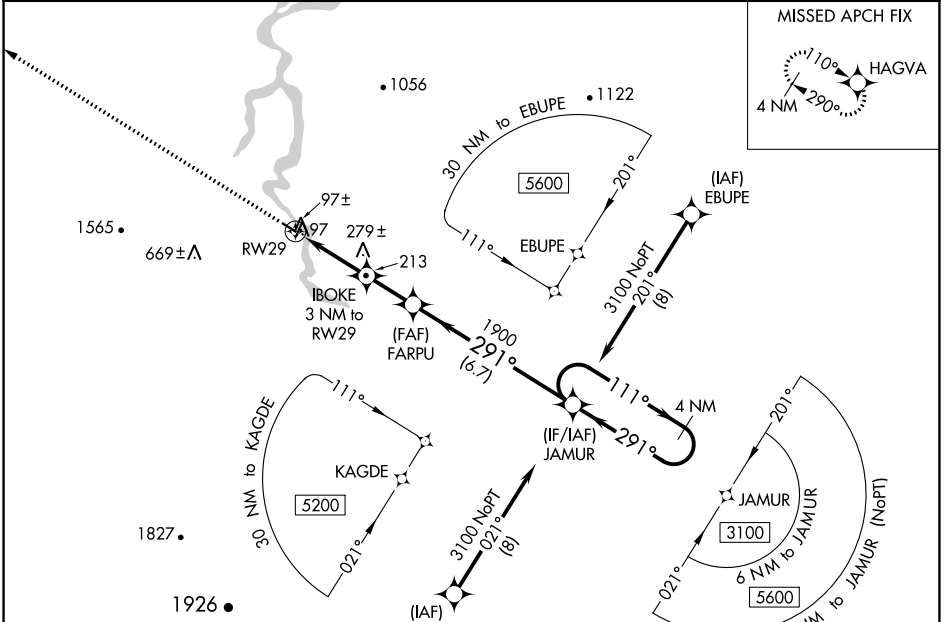

ELEV 29	TDZE 29
----------------	----------------

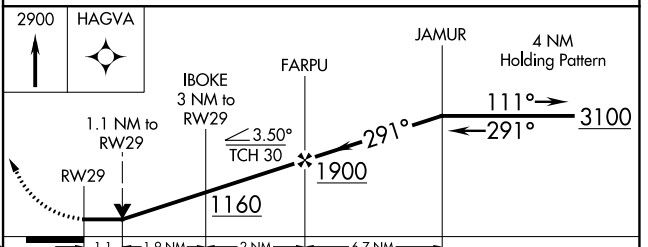
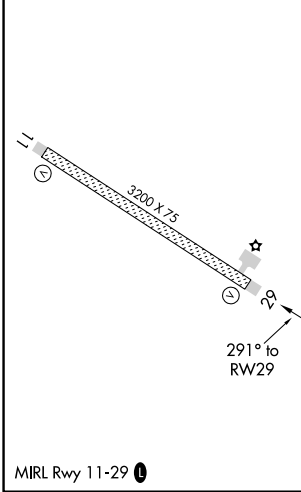

CATEGORY	A	B	C	D
LP MDA	480-1 451 (500-1)			NA
LNAV MDA	540-1	511 (600-1)	540-1 3/8 511 (600-1 3/8)	NA
☑ CIRCLING	540-1	511 (600-1)	640-1 3/4 611 (700-1 3/4)	NA

AK, 25 FEB 2021 to 22 APR 2021

AK, 25 FEB 2021 to 22 APR 2021